



# Cercas-Tel Diseño y Construcción

*Construyendo expectativas desde 2015*

## **Matriz Pachuca**

Carr. México-Pachuca km 77.5, Loc. # 6, Frente al cruce de Tellez, Acayuca, Zapotlán, Hgo. C.P. 42191  
Tel. (771) 285 22 85 - (771) 474 35 08 Cel. (771) 321 37 87

Cercas – Impermeabilizantes – Muros Verdes –  
Muros 3D – Diseño – Construcción

# PRODUCTOS Y SERVICIOS



## Cercas

- Malla Ciclónica.....3**
- Malla Triple Nudo Urbana.....4**
- Malla Hexagonal.....5**
- Malla Borreguera.....6**
- Malla Criba.....7**
- Malla Rígida Ondulada.....8**
- Metal Desplegado.....9**
- Malla Plafón.....10**
- Multimalla.....11**
- Malla Sombra.....12**
- Reja Acero.....13**
- Barrera Antideslumbrante.....14**
- Tubería Galvanizada.....15**
- Concertina.....16**
- Alambre de Púas.....17**
- Alambre Galvanizado.....18**
- Cinta Rompevientos.....19**
- Espinal.....20**

## Impermeabilizantes

- Impermeabilizantes Asfálticos y Acrílicos.....21**



## Muros Verdes Artificiales

- Follaje Artificial.....23**



## Muros 3D Decorativos

- Muros 3D Decorativos.....31**



## Diseño y Construcción

- Diseño y Construcción.....41**





# MALLA CICLONICA

## ESPECIFICACIONES

- ROLLOS DE 20 MTS Y 10 MTS, ABERTURAS 55\*55 MM, 63\*63 MM, 69\*69 MM.
- FABRICACION CON ALAMBRE .
- ABERTURAS EN GALVANIZADO POR INMERSION EN CALIENTE.
- MALLA PVC DE ALTA CALIDAD RESISTENTE A LA INTEMPERIE.

ALT.	C. 10.5	C. 11	C. 11.5	C. 12.5	C. 13	C. 13.5	PVC 10.5	PVC 11.0
1.00	*	*	*	*	*	*	*	*
1.25	*	*	*	*	*	*	*	*
1.50	*	*	*	*	*	*	*	*
1.75	*	*	*	*	*	*	*	*
2.00	*	*	*	*	*	*	*	*
2.50	*	*	*	*	*	*	*	*
3.00	*	*	*	*	*	*	*	*



Tenemos accesorios  
y mas para  
instalaciones de  
malla

[www.cercasteldisenoyconstruccion.com](http://www.cercasteldisenoyconstruccion.com)

(771) 321 37 87



**Cercas-Tel**

# MAILLA TRIPLA NUDO URBANA



ALTURA	ABERTURA	# ALAM	M.L.
1.51		18	
2.04	3" x 3.5"	24	50
2.13		25	
1.98	3" x 6"	14	



**USOS:**

- RESIDENCIALES, INDUSTRIALES, RECREATIVOS Y AGROPECUARIOS.
- MISMOS USOS QUE LA MALLA CICLONICA PERO CON MAYORES VENTAJAS EN SEGURIDAD, DURABILIDAD.
- ES VERSATIL YA QUE SE COMPLEMENTA CON ALAMBRE PUA, MALLA SOMBRA, CONCERTINA.

**CARACTERISTICAS:**

- ALAMBRES DE ALTA TENSION, FUERTES Y RESISTENES.
- TRIPLE GALVANIZADO, RESISTENTE A LA OXIDACION.
- MAS RIGIDA QUE LAS OTRAS MALLAS POR SU TRIPLE NUDO.
- CALIBRE INTERIOR 12.5 Y CALIBRE ORILLERO 12.0

**VENTAJAS:**

- FACIL MANEJO.
- MAYOR RESISTENCIA A LA CORROSION.
- MAYOR FIRMEZA.

[www.cercasteldisenoyconstruccion.com](http://www.cercasteldisenoyconstruccion.com)

(771) 321 37 87



**Cercas-Tel**



# MALLA HEXAGONAL ...

## USOS:

- JAULAS PARA ANIMALES PEQUEÑOS.
- CASETAS AVICOLAS Y ALMACENES DE GRANO.
- AISLAR MUROS EXTERIORES Y AZOTEAS.
- ENJARRE DE CEMENTO EN MUROS.
- PROTECCION DE JARDINES Y HUERTOS.
- GUIA DE ENREDADERAS.

## CARACTERISTICAS:

- ALAMBRES SUAVES Y MALEABLES.
- ACABADO GALVANIZADO O PVC.
- HEXAGONO SIMETRICO.
- ALAMBRE DE REFUERZO CADA 30 CM.

## VENTAJAS:

- FACIL MANEJO.
- MAYOR RESISTENCIA A LA CORROSION.
- MAYOR FIRMEZA.

CALIBRE	ABERTURA MM	ALT.	M.L.
23	13	0.90	45
22	20	0.90	45
22	25	1.00	45
22	25	1.20	45
22	25	1.50	45
22	25	1.75	45
20	38	1.50	45
20	38	1.75	45
20	50	1.50	45
20	50	1.75	45



[www.cercasteldisenoyconstruccion.com](http://www.cercasteldisenoyconstruccion.com)

(771) 321 37 87



**Cercas-Tel**

# MALLA BORREGERA

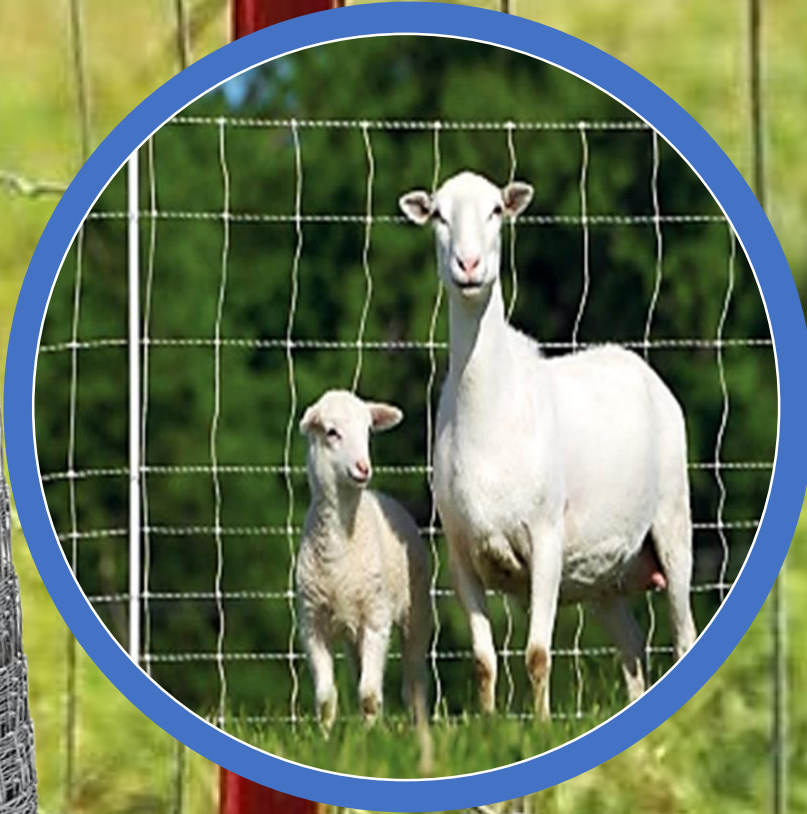

ALTIMRA	CAL. 14.5 INTERMEDIOS CAL. 11 EXTREMOS
1.00	ROLLOS DE 50 MTS.
1.20	
1.67	
2.00	
2.50	

**USOS:**

- BOVINOS.
- OVINOS.
- CAPRINOS.
- AGRICOLA.

**CARACTERISTICAS:**

- ACABADO GALVANIZADO COMERCIAL.
- CURBA DE TENSION NUDO TIPO BISAGRA.

**VENTAJAS:**

- RESISTENTE A LA CORROSION.
- SU CURVA DE TENSION ABSORBE LOS CAMBIOS CLIMATOLOGICOS Y LOS RECARGONES DEL GANADO.

[www.cercasteldisenoyconstruccion.com](http://www.cercasteldisenoyconstruccion.com)

(771) 321 37 87



**Cercas-Tel**

# MALLA CRIBA

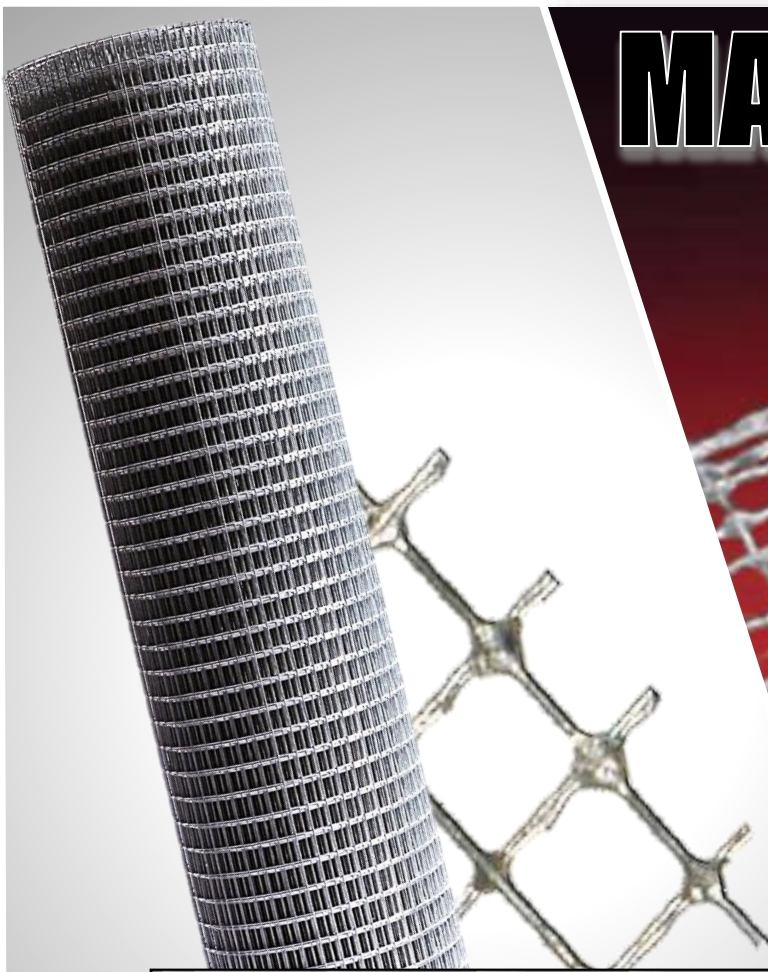

## USOS:

- JAULAS PARA PAJAROS.
- ARREGLOS FLORALES.
- CERNIR/CRIBAR ARENA

## CARACTERISTICAS:

- ACABADO GALVANIZADO POR INMERSION EN CALIENTE.

## VENTAJAS:

- FABRICADA CON ALAMBRE DE ACERO SUAVE QUE FACILITA SU MANEJO..

MEDIDA MM	CALIBRE	ANCHO ML	LARGO ML
2 X 2	19	0.91	30 Y 10
3 X 3	21	0.91	30 Y 10
4 X 4	23	0.91	30 Y 10
5 X 5	24	0.91	30 Y 10
6 X 6	25	0.91	30 Y 10
8 X 8	26	0.91	30 Y 10

[www.cercasteldisenoyconstruccion.com](http://www.cercasteldisenoyconstruccion.com)

(771) 321 37 87



**Cercas-Tel**

**ABERTURA 50 X 50 MM ROLLO DE 20 ML**

ALTURA	CAL. 11.5	CAL. 10.5	CAL. 9	CAL. 8	CAL. 6
1.00 MTS	*	*	*	*	*
1.25 MTS	*	*	*	*	*
1.50 MTS	*	*	*	*	*
1.75 MTS	*	*	*	*	*
2.00 MTS	*	*	*	*	*

**ABERTURA 40 X 40 MM ROLLO DE 20 ML**

ALTURA	CAL. 11.5	CAL. 10.5	CAL. 9	CAL. 8	CAL. 6
1.00 MTS	*	*	*	*	*
1.25 MTS	*	*	*	*	*
1.50 MTS	*	*	*	*	*
1.75 MTS	*	*	*	*	*
2.00 MTS	*	*	*	*	*

**ABERTURA 30 X 30 MM ROLLO DE 20 ML**

ALTURA	CAL. 11.5	CAL. 10.5	CAL. 9	CAL. 8	CAL. 6
1.00 MTS	*	*	*	*	*
1.25 MTS	*	*	*	*	*
1.50 MTS	*	*	*	*	*
1.75 MTS	*	*	*	*	*
2.00 MTS	*	*	*	*	*

**ABERTURA 25 X 25 MM ROLLO DE 20 ML**

ALTURA	CAL. 11.5	CAL. 10.5	CAL. 9	CAL. 8	CAL. 6
1.00 MTS	*	*			
1.25 MTS	*	*			
1.50 MTS	*	*			
1.75 MTS	*	*			
2.00 MTS	*	*			

# MAJLA RIGIDA ONDULADA

**USOS:**

- HERRERIA, SEGURIDAD PERIMETRAL, CRIBA O TAMIZ, INDUSTRIAL Y AUTOMOTRIZ

**CARACTERISTICAS:**

- ALAMBRE GALVANIZADO POR INMERSION EN CALIENTE.



[www.cercasteldisenoyconstruccion.com](http://www.cercasteldisenoyconstruccion.com)

(771) 321 37 87



**Cercas-Tel**



# METAL DESPLIEGADO

## USOS:

- HERRERIA, PISOS, FILTROS, JAULAS Y ESTRUCTURAS

## CARACTERISTICAS:

- ACABADO GALVANIZADO SIN PLANCHAR



ROMBOS  
UNIFORMES

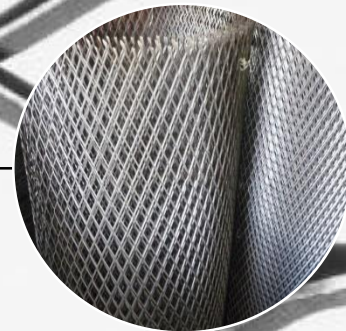

## ROLLO DE 0.91 MTS X 11 ML

CALIBRE	AB (MM)	AB (MM)	AB (MM)
22	11X22	12X30	
20	11X22	12X30	20X40
18	11X22	12X30	20X40
16	11X22	12X30	20X40
14		12X30	20X40

[www.cercasteldisenoyconstruccion.com](http://www.cercasteldisenoyconstruccion.com)

(771) 321 37 87



**Cercas-Tel**

# MALLA PLAFON

ROLLO DE 0.91 MTS X 22 ML

CALIBRE	AB (MM)
26	11X27



#### USOS:

- IDEAL PARA TECHOS, MUROS, PAREDES FALSAS, FACHADAS, PLAFONES, ETC.

#### CARACTERISTICAS:

- ACABADO GALVANIZADO SIN PLANCHAR

[www.cercasteldisenoyconstruccion.com](http://www.cercasteldisenoyconstruccion.com)

(771) 321 37 87



**Cercas-Tel**

# MULTIMALLA

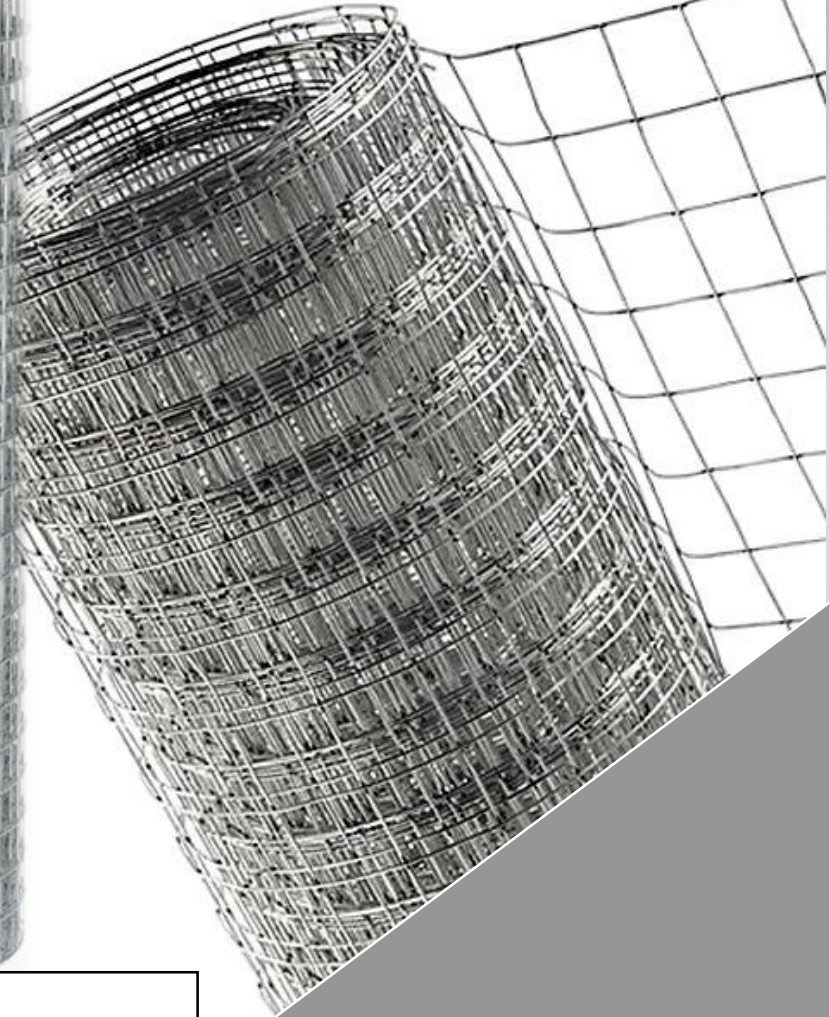

## ROLLO DE 20 ML

ALTURA MTS	CALIBRE	AB (CM)
1.00	14	5X5
1.22	14	5X5
1.00	14	5X10
1.22	14	5X10

### USOS:

- EXHIBIDORES DE MERCANCIAS, ETC.

### CARACTERISTICAS:

- UNIONES FIRMEMENTE SOLDADAS, ACABADO LISO.

[www.cercasteldisenoyconstruccion.com](http://www.cercasteldisenoyconstruccion.com)

(771) 321 37 87



**Cercas-Tel**

# MAILLA SOMBRA

## USOS:

- TOLDOS PARA PROTEGER DEL SOL A PERSONAS, ESTACIONAMIENTOS, PATIOS Y JARDINES.
- SOBRE MALLA CICLONICA PARA DAR PRIVACIDAD Y CORTAR EL VIENTO.
- CANCHA DE TENIS, CAMPOS DE GOTCHA Y ZONAS DEPORTIVAS, ETC.

## CARACTERISTICAS:

- COMPUESTA DE MONOFILAMENTOS DE POLIETILENO DE ALTA DENSIDAD CON ADITIVOS UV QUE AUMENTAN SU VIDA UTIL.
- DURACION DE 5 A 7 AÑOS.
- ROLLO DE 3.70 M ANCHO X 100 M LARGO.
- CONFECCION CON HILO DE MONOFILAMENTO, ADEMAS DE REFORZAR EL PERIMETRO CON CINTA DE REFUERZO U OJILLOS PARA SUJECION.

## VENTAJAS:

- ESTETICA, REDUCE HASTA 10° DE TEMPERATURA.



TIPO DE MALLA	DENSIDAD %	COLOR
ARQUITECTONICA	95	TERRACOTA, BEIGE, ROJA, NEGRA, AZUL, ARCILLA
RASCHEL	95	BEIGE, VERDE, NEGRA, AZUL, TERRACOTA
POLIETILENO	95	COMBINACION DE COLORES
	90	AZUL, VERDE, BEIGE, NEGRA
	80	NEGRA Y VERDE
	70	NEGRA Y VERDE
	50	NEGRA Y VERDE
	35	NEGRA Y VERDE

[www.cercasteldisenoyconstruccion.com](http://www.cercasteldisenoyconstruccion.com)

(771) 321 37 87



**Cercas-Tel**

# REJA ACERO

PRODUCTO FABRICADO CON ALAMBRE GALVANIZADO DE ALTA RESISTENCIA, CON ACABADO DE ZINC, ELECTROSOLDADA Y RECUBIERTA CON PINTURA TERMOENDURECIDA PARA MAYOR DURACION CONTRA LA OXIDACION.

Durabilidad

Funcional

Resistente

Segura

Estética

Fácil instalación

### VENTAJAS:

- COLORES ESTANDAR: VERDE, BLANCO, ROJO, AZUL, AMARILLO, NEGRO Y GRIS.
- USOS: INDUSTRIAL, RESIDENCIAL, COMERCIAL, AREAS RECREATIVAS, ESCUELAS, TURISMO, ETC.,

ALT	L	CAL	POSTE	CAL	DIMENS	ABRAZ
0.63	2.50	6	1.00	16	2" X 2"	2
1.00	2.50	6	1.50	16	2" X 2"	2
1.50	2.50	6	2.00	16	2" X 2"	3
2.00	2.50	6	2.50	16	2" X 2"	4
2.50	2.50	6	3.00	16	2" X 2"	5

[www.cercastelisenoyconstruccion.com](http://www.cercastelisenoyconstruccion.com)

(771) 321 37 87



**Cercas-Tel**

# BARRERA ANTIDESLUMBRANTE

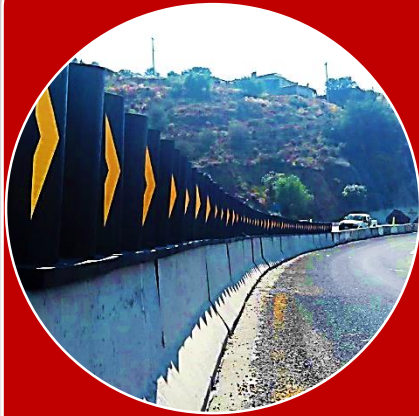

Autopistas



Carreteras



Barrera armada



Plano

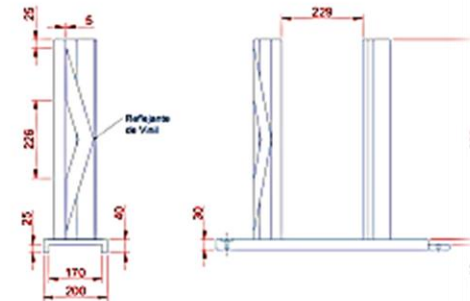

\* BARRERA DISEÑADA PARA EVITAR DESLUMBRAMIENTO

Ensamble de 3 piezas (vista superior)

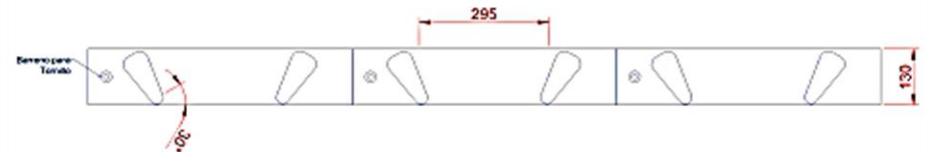

\* PRODUCTO DE LARGA DURABILIDAD CON ADITIVO RETARDANTE A LA FLAMA

\* FABRICADA EN POLIETILENO DE MEDIA DENSIDAD

\* REFLEJANTE EN COLOR AMARILLO MARCA 3M

\* FACIL INSTALACION Y ECONOMICA

\* ADITIVOS PARA MEJORAR LAS PROPIEDADES MECANICAS AL IMPACTO

\* PRODUCTO DISEÑADO PARA BARRERAS INSTALADAS EN CARRTERAS

Producto



100 % Reciclado



[www.cercasteldisenoyconstruccion.com](http://www.cercasteldisenoyconstruccion.com)

(771) 321 37 87



**Cercas-Tel**

# TUBERIA GALVANIZADA



## ESPECIFICACIONES

- TUBERIA FABRICADA CON LAMINA DE ACERO GALVANIZADO POR INMERSION EN CALIENTE INTERNA Y EXTERNAMENTE.



DIAMETRO	GALVANIZADO									CEDULA		
	C. 22 6 M	C. 20 6 M	C. 20 4.80 M	C. 22 4.80 M	C. 18 4.80 M	C. 18 6 M	C. 18 7 M	C. 16 6 M	C. 14 6 M	DIAMETRO	CED 30 6 M	CED 40 6.40 M
1 3/8" 33 MM	*	*				*				1"	*	*
1 1/2" 38 MM	*	*				*		*				
1 5/8" 42 MM	*	*			*	*		*		1 1/4"	*	*
1 7/8" 48 MM	*	*	*	*	*	*		*		1 1/2"	*	*
2 3/8" 60 MM		*	*		*	*	*	*	*	2"	*	*
2 7/8" 73 MM					*	*	*	*	*	2 1/2"	*	*
3 1/2" 89 MM								*	*	3"	*	*
4 1/2" 114 MM										4"	*	*



[www.cercasteldisenoyconstruccion.com](http://www.cercasteldisenoyconstruccion.com)

(771) 321 37 87



**Cercas-Tel**



- VENTAJAS:**
- EXCELENTE PROTECCION.
  - NO REQUIERE MANTENIMIENTO.
  - LARGA DURACION.
  - LOS DISEÑOS MAS PELIGROSOS DEL MERCADO.

# CONCERTINA

- USOS PRINCIPALES:**
- PROTECCION PARA USO INDUSTRIAL Y PRIVADO.
    - PENALES DE MAXIMA SEGURIDAD.
  - SEGURIDAD EN LUGARES PUBLICOS (COLEGIOS, CASAS, INSTITUCIONES PUBLICAS O PRIVADAS).

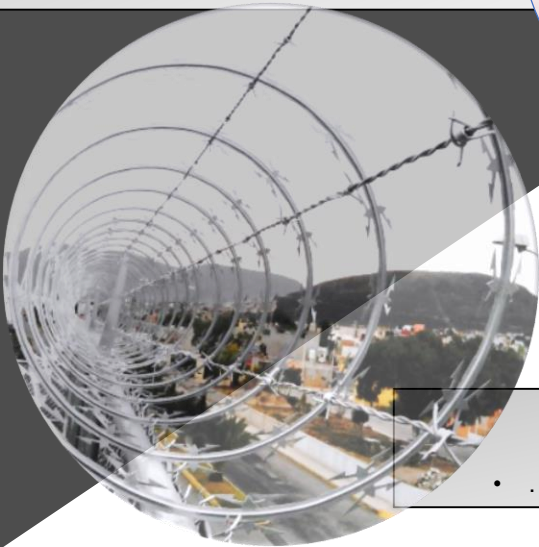

- ESPECIFICACIONES:**
- FABRICADA EN ACERO GALVANIZADO.
  - REFUERZO O ALMA DE ALAMBRE GALVANIZADO

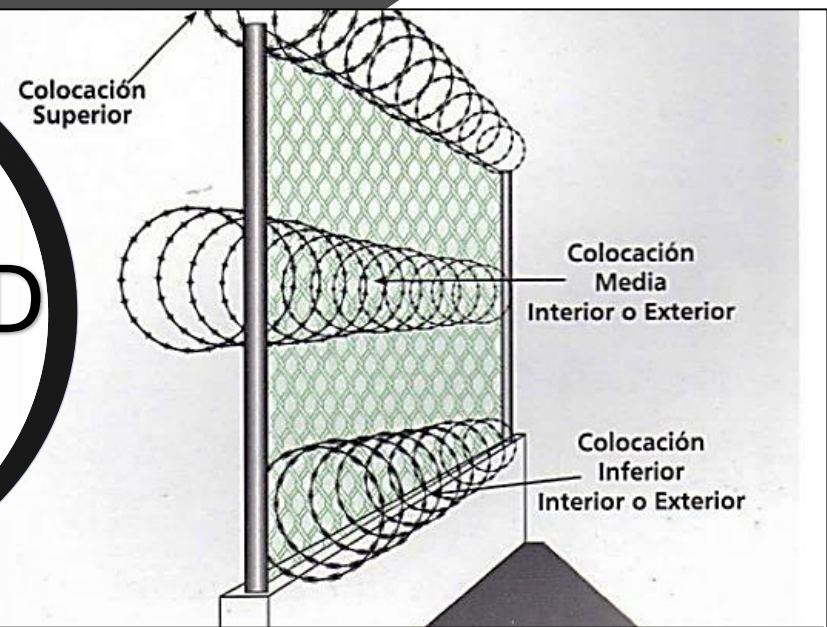

DISEÑO	DIAMETRO	LONGITUD ROLLO	CAL. ALMA	LONGITUD CUCHILLA	SEPARACION CUCHILLAS
SENCILLA RECTA	45 CM	8 ML	12.5	6.4 CM	10 CM
MILITAR SENCILLA ARPON	45 CM	8 ML	12.5	6.4 CM	10 CM
MILITAR DOBLE ARPON	45 CM	4 ML	12.5	6.4 CM	10 CM

[www.cercasteldisenoyconstruccion.com](http://www.cercasteldisenoyconstruccion.com)

(771) 321 37 87



**Cercas-Tel**



# ALAMBRE DE PUAS

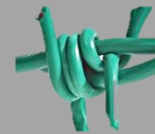

## ALAMBRE DE PUAS VAQUERO DE 17 KG DE 360, 300 Y 250 ML.

- FABRICADO CON ALAMBRE CALIENTE.
- CALIBRE 15.5 EN ALAMBRE Y CALIBRE 16.5 EN LAS PUAS.
- LA PUA ESTA FABRICADA CON CUATRO PUNTAS CON UNA DISTANCIA DE 5" ENTRE PUA Y PUA.



## ALAMBRE DE PUAS BRONCO DE 34 KG DE 355 ML.

- FABRICADO CON ALAMBRE GALVANIZADO POR INMERSION EN CALIENTE.
- CALIBRE 12.5 EN ALAMBRE Y CALIBRE 14 EN LAS PUAS.
- LA PUA ESTA FABRICADA CON CUATRO PUNTAS CON UNA DISTANCIA DE 5" ENTRE PUA Y PUA.



[www.cercasteldisenoyconstruccion.com](http://www.cercasteldisenoyconstruccion.com)

(771) 321 37 87



**Cercas-Tel**

# ALAMBRE LISO GALVANIZADO

## ESPECIFICACIONES:

- ALAMBRE DE ACERO SUAVES GALVANIZADOS POR INMERSION CALIENTE.
- UNICAMENTE EN CALIBRES 10.0, 11.0, 12.5, 13.0 Y 18
- SE VENDE A GRANDEL DESDE UN 1 KG.



[www.cercasteldisenoyconstruccion.com](http://www.cercasteldisenoyconstruccion.com)

(771) 321 37 87



**Cercas-Tel**



# ESPINAL

PIEZAS DE 1 MT LINEAL  
CON 8 MAGUEYES Y 8  
PUNTAS



Protección en rejas o bardas perimetrales



Puntas afiladas de fácil instalación

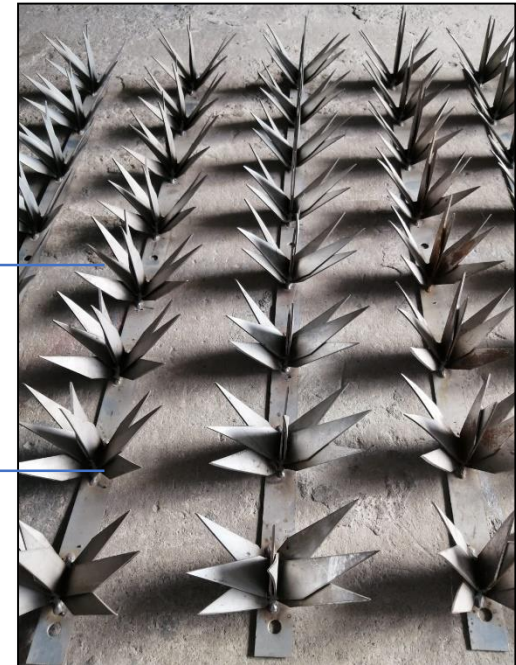

[www.cercasteldisenoyconstruccion.com](http://www.cercasteldisenoyconstruccion.com)  
(771) 321 37 87



**Cercas-Tel**

# IMPERMEABILIZANTE

**¡QUE LA LLUVIA  
Y EL CALOR  
SE QUEDEN AFUERA!**

**IMPERMEABILIZANTES  
TERMICOS.  
CALIDAD QUE DURA...**



[www.cercastel disenoyconstruccion.com](http://www.cercastel disenoyconstruccion.com)

(771) 321 37 87



**Cercas-Tel**

# IMPERMEABILIZANTE

## USOS:

- IMPERMEABILIZANTE PARA LOSAS DE CONCRETO Y LAMINA.
- ASFALTICOS Y ACRILICOS DE 3, 5, 7 Y 10 AÑOS.
- APLICACIÓN EN FRIO Y EN CALOR.
- SBS FIBRA DE VIDRIO Y POLIESTER DE 3.5, 4.0 Y 4.5 MM DE ESPESOR.
- COLOR ROJO TERRACOTA, VERDE Y BLANCO.
- GARANTIA DE 3 A 10 AÑOS.



[www.cercasteldisenoyconstruccion.com](http://www.cercasteldisenoyconstruccion.com)

(771) 321 37 87



**Cercas-Tel**



# MUROS VERDES (FOLLAJE ARTIFICIAL DECORATIVO)

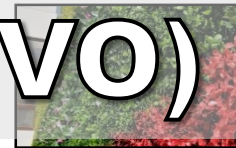

*.....Cero mantenimiento y apariencia Natural.....*

[www.cercasteldisenoyconstruccion.com](http://www.cercasteldisenoyconstruccion.com)

(771) 321 37 87



**Cercas-Tel**

## CARACTERISTICAS:

- MATERIAL DE LA HOJA: PVC VIRGEN
- ESPERANZA DE VIDA: 10 AÑOS
- VISIBILIDAD: 10%
- MOSAICO: 4 PZAS DE 50 X 50 CM

## VENTAJAS:

- LUCE NATURAL.
- CUENTA CON PROTECCION UV.
- AISLANTE ACUSTICO Y TERMICO.
- NO REQUIERE MANTENIMIENTO, ABONO, NI RIEGO.
- NO ES TOXICO.
- ES HIPOALERGENICO.
- CONTIENE UN RETARDANTE DE FLAMA

## USOS:

- EN FACHADAS, EN MUROS, EN MALLA CICLONICA, EN HERRERIA Y FALSO PLAFON.

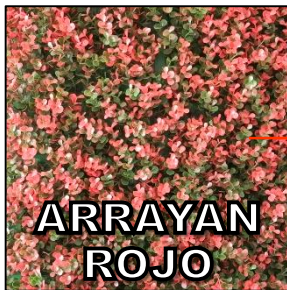

[www.cercasteldisenoyconstruccion.com](http://www.cercasteldisenoyconstruccion.com)

(771) 321 37 87



Cercas-Tel



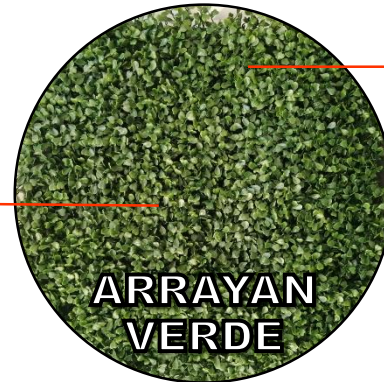
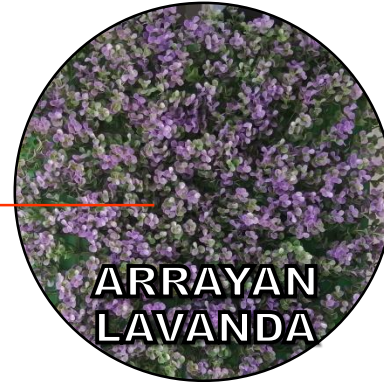
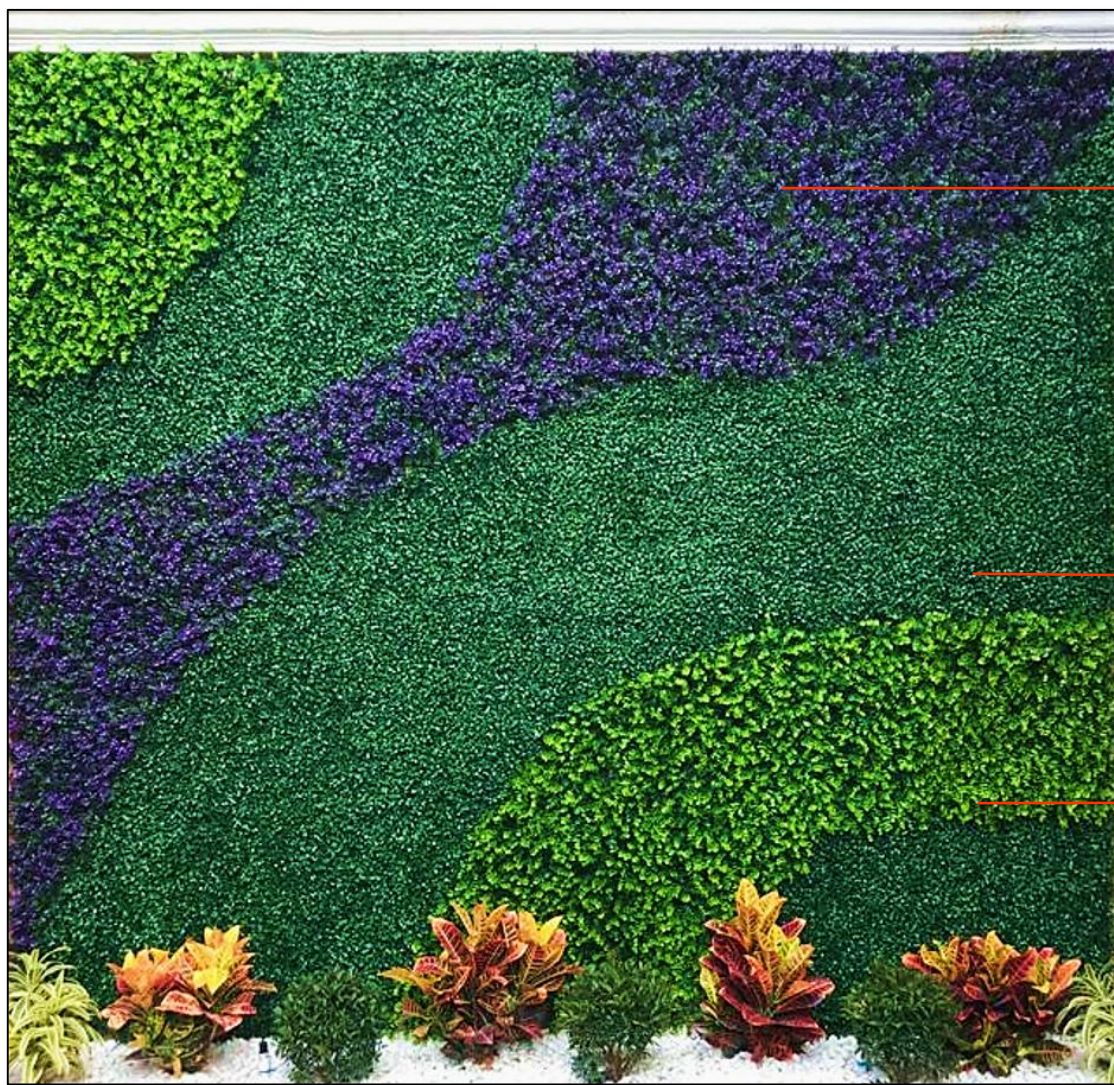

**ES IDEAL PARA AUMENTAR LA LUMINOSIDAD Y LA ATENCION AL DETALLE TODOS LOS MODELOS DAN UNA APARIENCIA FRONDOSA Y NATURAL.**

[www.cercasteldisenoyconstruccion.com](http://www.cercasteldisenoyconstruccion.com)

(771) 321 37 87



**Cercas-Tel**

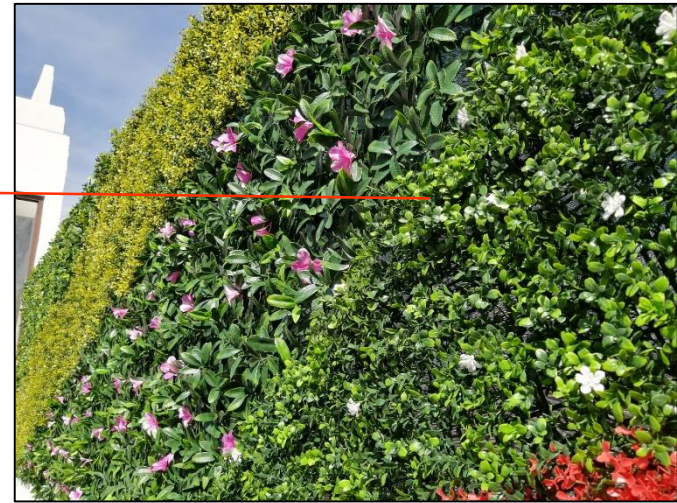
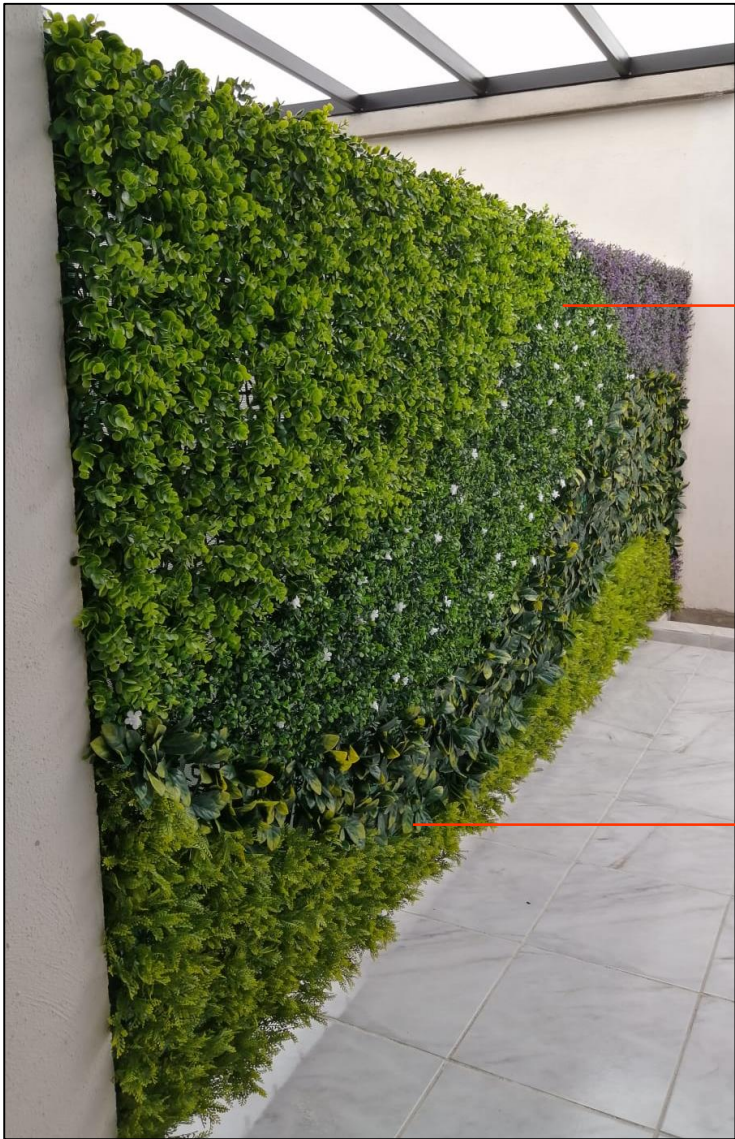

**DIFERENTES TEXTURAS Y COLORES QUE RESALTAN E ILUMINAN EL ESPACIO**



[www.cercasteldisenoyconstruccion.com](http://www.cercasteldisenoyconstruccion.com)

(771) 321 37 87



**Cercas-Tel**



**ITALIA**



**JAZMIN**

**USO INTERIOR Y EXTERIOR**

**FÁCIL INSTALACION EN FACHADAS**

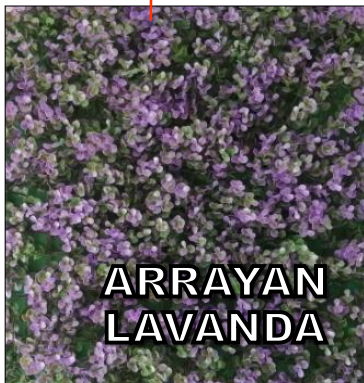
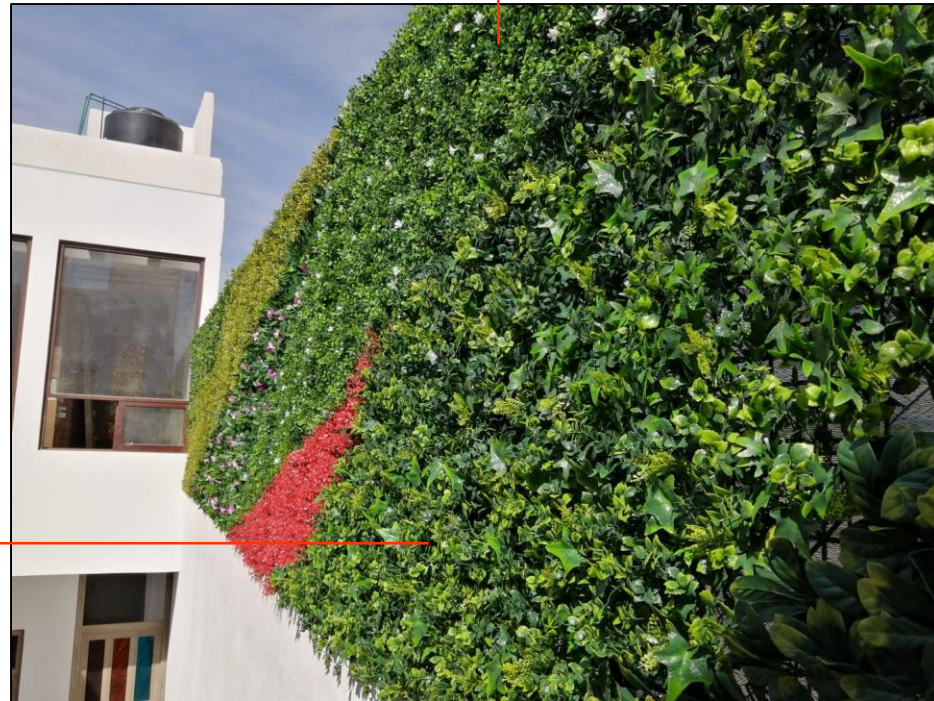

**ARRAYAN  
LAVANDA**



**TROPICAL**

[www.cercasteldisenoyconstruccion.com](http://www.cercasteldisenoyconstruccion.com)

(771) 321 37 87



**Cercas-Tel**



**ARRAYAN  
LIMON**

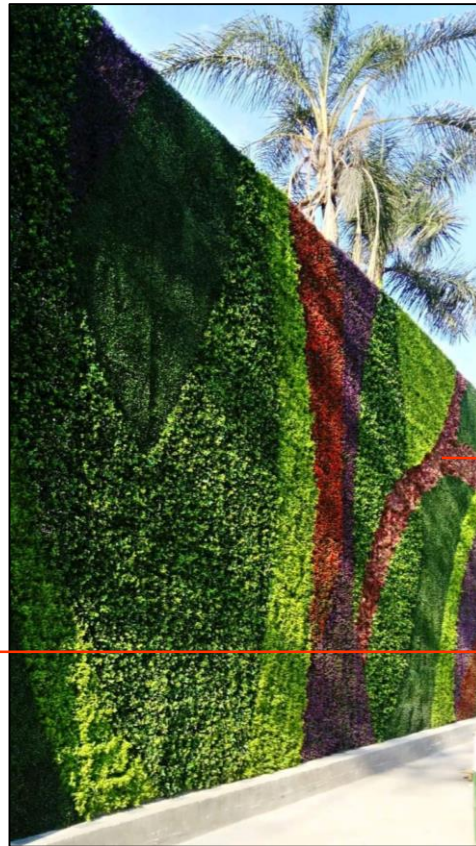

**MAPLE  
ROJO**



**ESPACIOS  
COLORIDOS**

**ESPACIOS DISTINTIVOS**

[www.cercasteldisenoyconstruccion.com](http://www.cercasteldisenoyconstruccion.com)

(771) 321 37 87



**Cercas-Tel**

## LIBRES DE MANTENIMIENTO

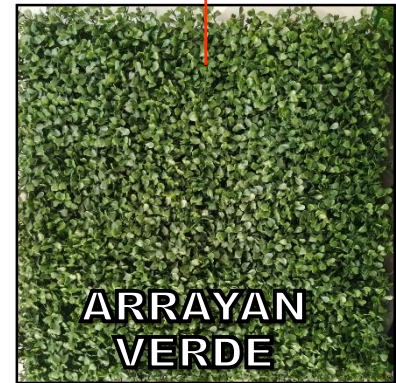

## FACILES DE INSTALAR

[www.cercasteldisenoyconstruccion.com](http://www.cercasteldisenoyconstruccion.com)

(771) 321 37 87



**Cercas-Tel**



**MAYA MORADA**



**ACAPULCO**



**AZALEA  
BLANCA**

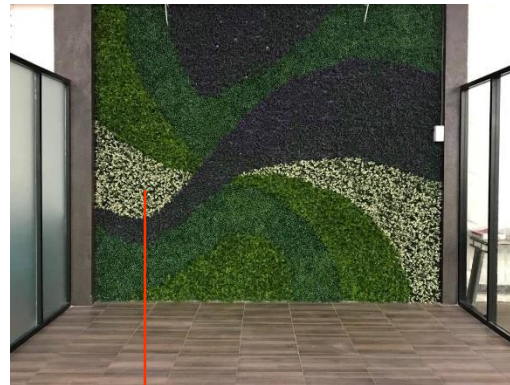

**APARIENCIA  
NATURAL**

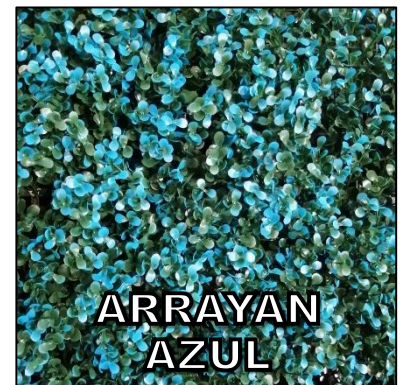

**ARRAYAN  
AZUL**

**EL TOQUE DE  
LUZ Y  
ELEGANCIA  
QUE  
NECESITAN TUS  
ESPACIOS**

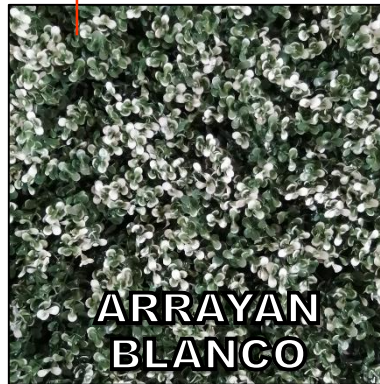

**ARRAYAN  
BLANCO**

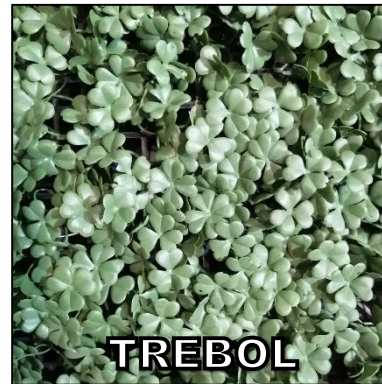

**TREBOL**

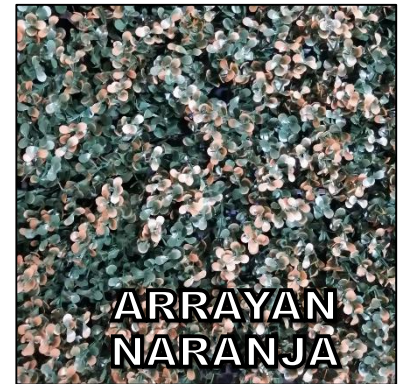

**ARRAYAN  
NARANJA**

[www.cercasteldisenoyconstruccion.com](http://www.cercasteldisenoyconstruccion.com)

(771) 321 37 87



**Cercas-Tel**

# MUROS DECORATIVOS 3D PVC

ES IDEAL PARA REMODELAR Y REVIVIR TUS ESPACIOS.

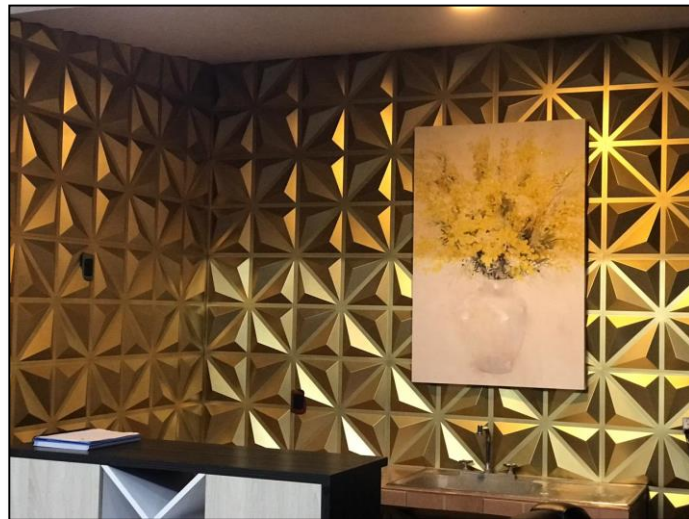

....."DISEÑA"....."DECORA"....."TRANSFORMA".....

[www.cercasteldisenoyconstruccion.com](http://www.cercasteldisenoyconstruccion.com)

(771) 321 37 87



**Cercas-Tel**

# MUROS DECORATIVOS 3D PVC

ES IDEAL PARA REMODELAR Y REVIVIR TUS ESPACIOS.

## VENTAJAS:

- LUCE ESPECTACULAR.
- DISEÑO ELEGANTE Y ESTETICO
- MATERIAL LIGERO
- FACIL INSTALACION
- RESISTENTE A LA HUMEDAD
- NO PROPAGA EL FUEGO
- AISLANTE TERMICO
- AISLANTE ACUSTICO (REDUCE HASTA EL 30% DE RUIDO)
- BIODEGRADABLE

## USOS:

- EN FACHADAS, EN MUROS DE ESCALERAS, HABITACIONES, COMEDORES, COMERCIOS, OFICINAS, ESTANCIAS, BAÑOS, COCINAS, ETC.

## CARACTERISTICAS:

- MOSAICO: 4 PZAS DE 50 X 50 CM
- PESO/PZA 350 g
- ESPESOR 1 MM
- MATERIAL 100% PVC
- COLOR BLANCO MATE



▪ Puedes instalarlos tu mismo.



▪ Necesitas cutter, flexómetro y regla.



▪ El PVC es un material flexible y fácil de manipular.



▪ Recomendamos el adhesivo de silicon "No más clavos".



▪ Planea tu instalación antes de colocar.



▪ Puedes aplicar estuco plástico en las juntas (opcional).



▪ Dar acabados con lija 220+



▪ Pinta con pistola del color deseado.

[www.cercasteldisenoyconstruccion.com](http://www.cercasteldisenoyconstruccion.com)

(771) 321 37 87



Cercas-Tel



# MUROS DECORATIVOS 3D PVC

MOD. T004

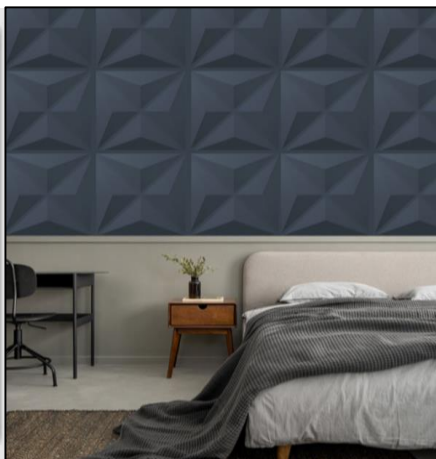
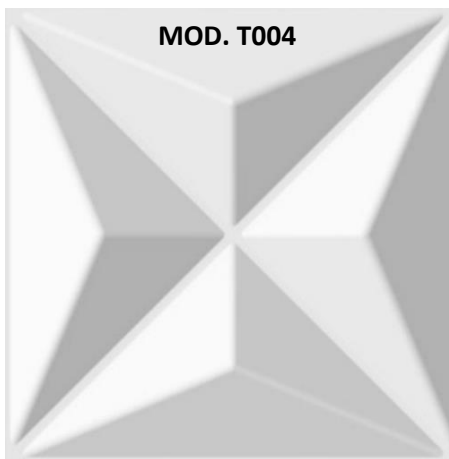

MOD. T007

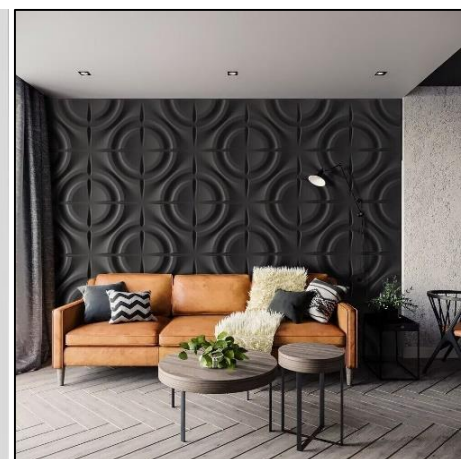

MOD. T008

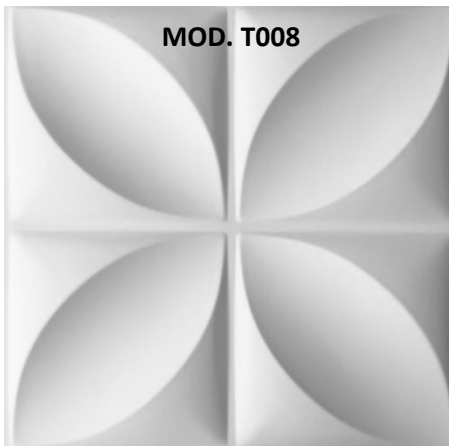

MOD. T020

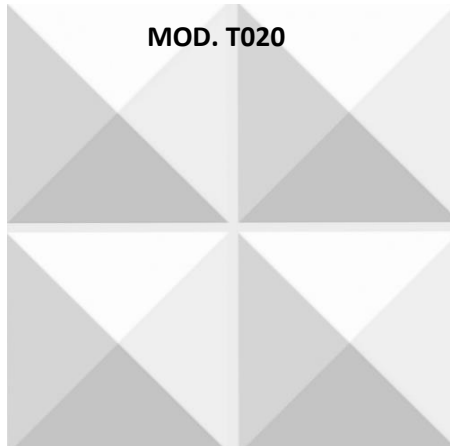

[www.cercasteldisenoyconstruccion.com](http://www.cercasteldisenoyconstruccion.com)

(771) 321 37 87



**Cercas-Tel**

# MUROS DECORATIVOS 3D PVC

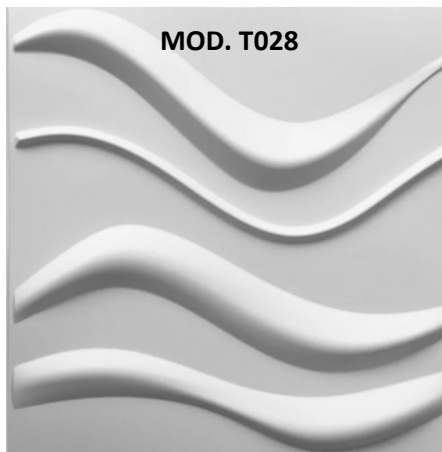
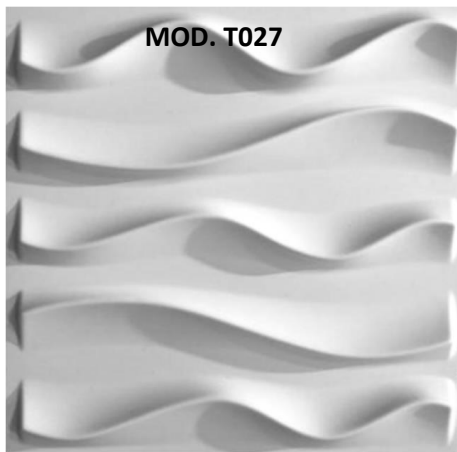
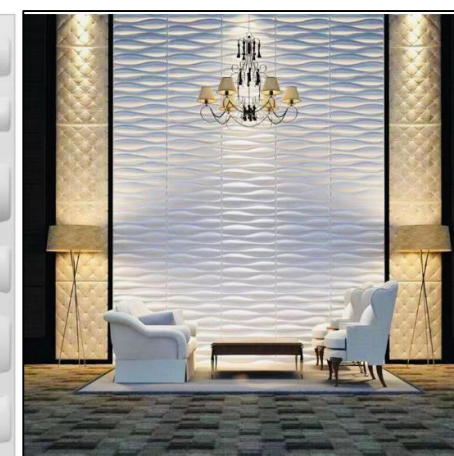
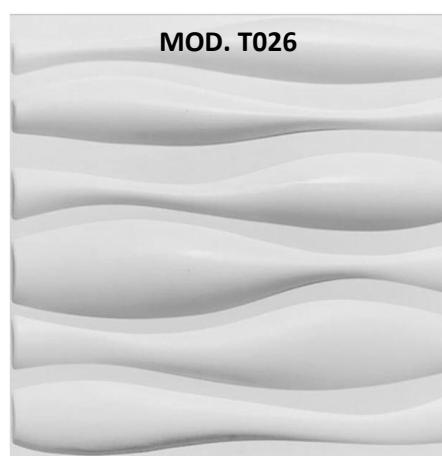
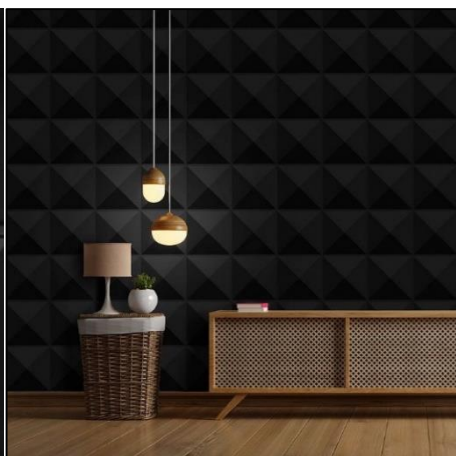

[www.cercasteldisenoyconstruccion.com](http://www.cercasteldisenoyconstruccion.com)

(771) 321 37 87



**Cercas-Tel**

# MUROS DECORATIVOS 3D PVC

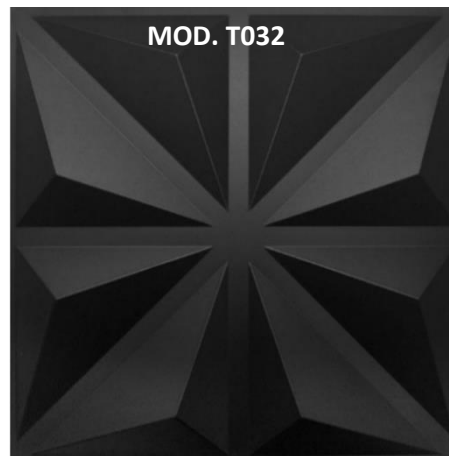
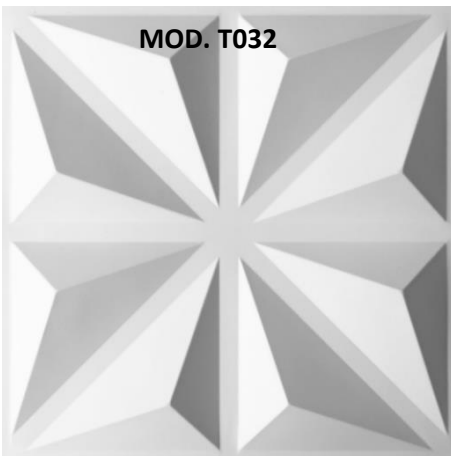
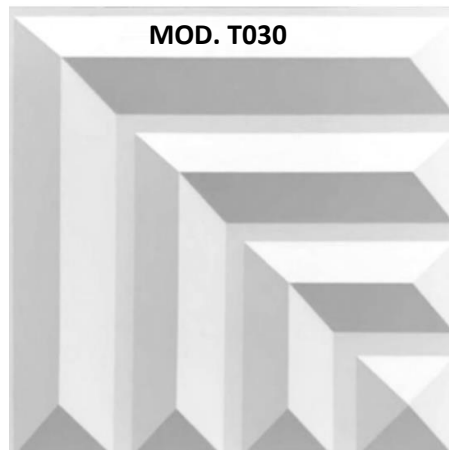
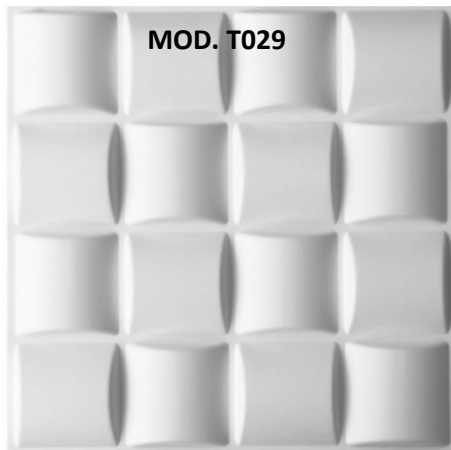

[www.cercasteldisenoyconstruccion.com](http://www.cercasteldisenoyconstruccion.com)

(771) 321 37 87



**Cercas-Tel**

# MUROS DECORATIVOS 3D PVC

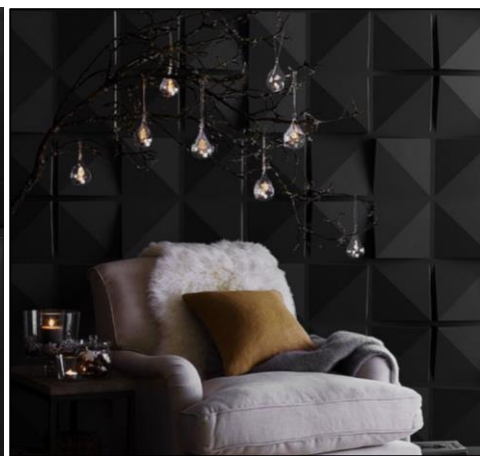
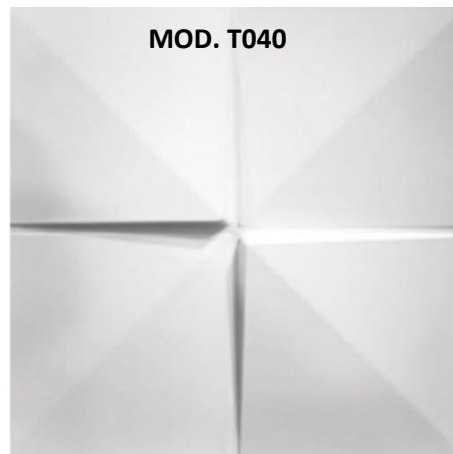
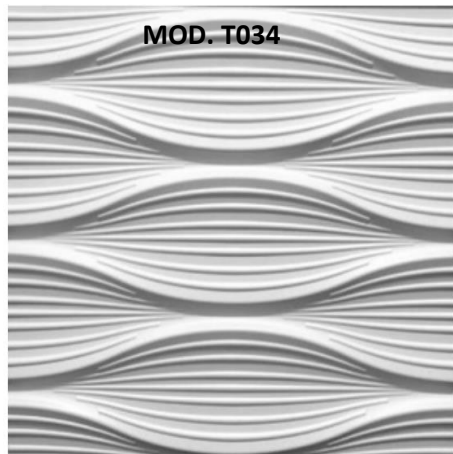

[www.cercasteldisenoyconstruccion.com](http://www.cercasteldisenoyconstruccion.com)

(771) 321 37 87



**Cercas-Tel**

# MUROS DECORATIVOS 3D PVC

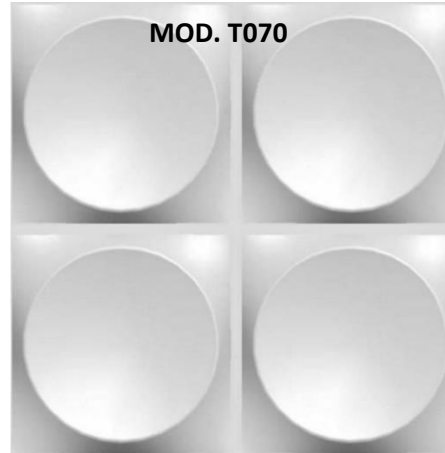
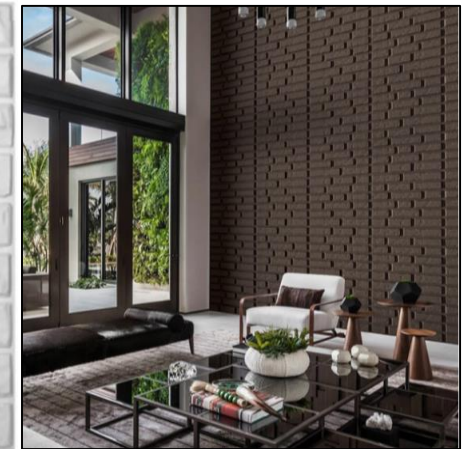
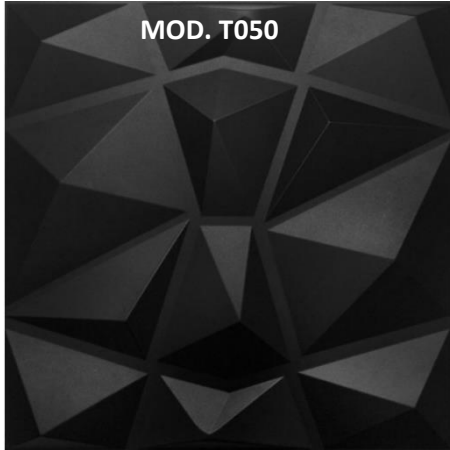

[www.cercasteldisenoyconstruccion.com](http://www.cercasteldisenoyconstruccion.com)

(771) 321 37 87



**Cercas-Tel**

# MUROS DECORATIVOS 3D PVC

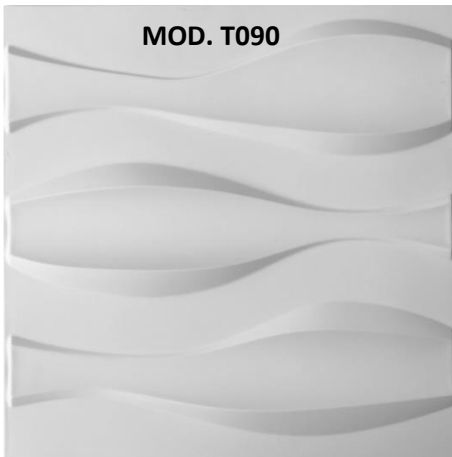
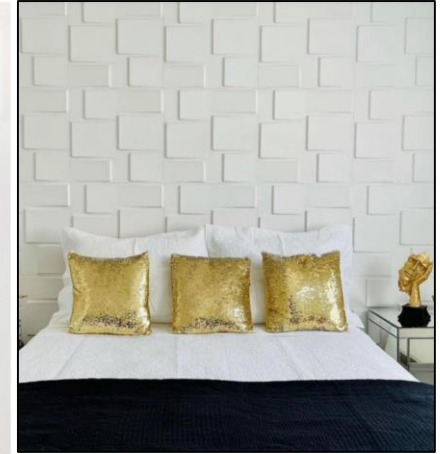
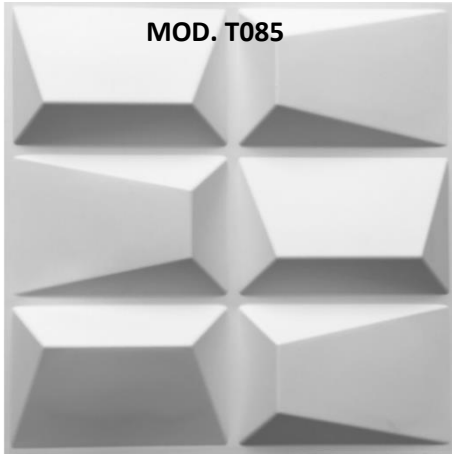

[www.cercasteldisenoyconstruccion.com](http://www.cercasteldisenoyconstruccion.com)

(771) 321 37 87



**Cercas-Tel**

# MUROS DECORATIVOS 3D PVC

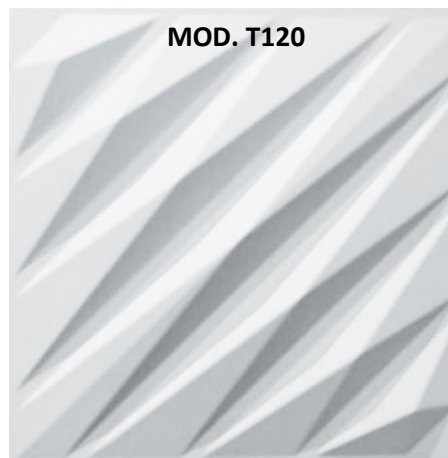
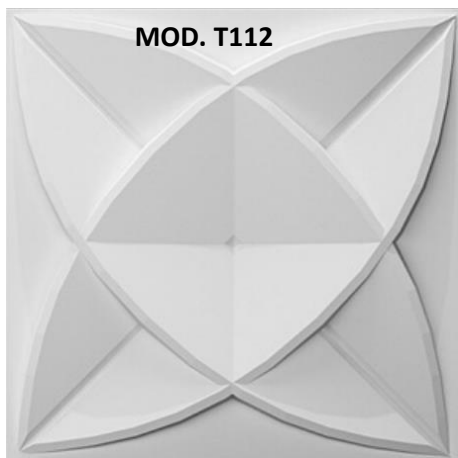
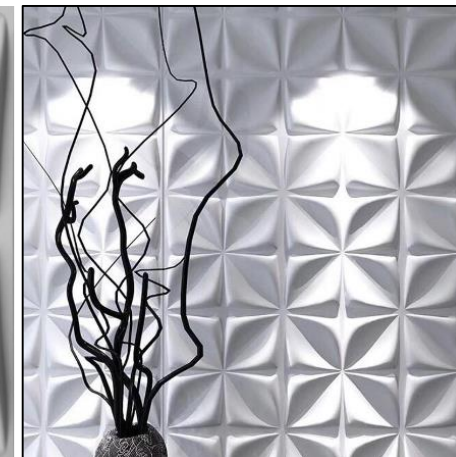
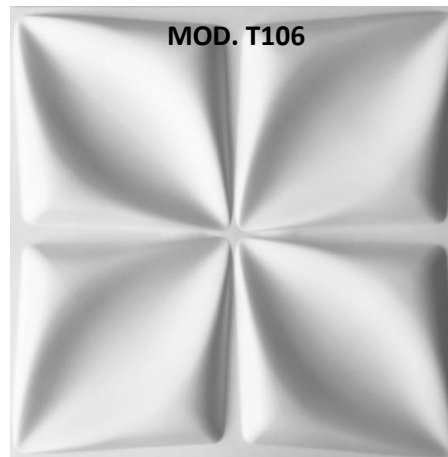

[www.cercasteldisenoyconstruccion.com](http://www.cercasteldisenoyconstruccion.com)

(771) 321 37 87



**Cercas-Tel**

# MUROS DECORATIVOS 3D PVC

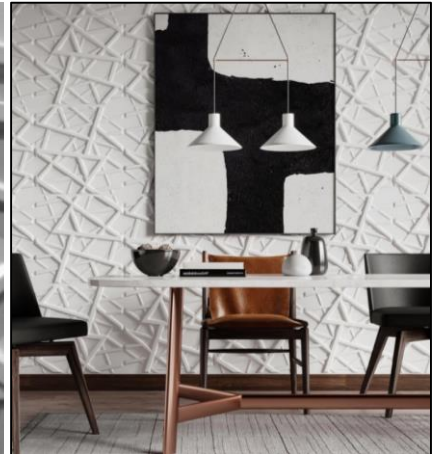
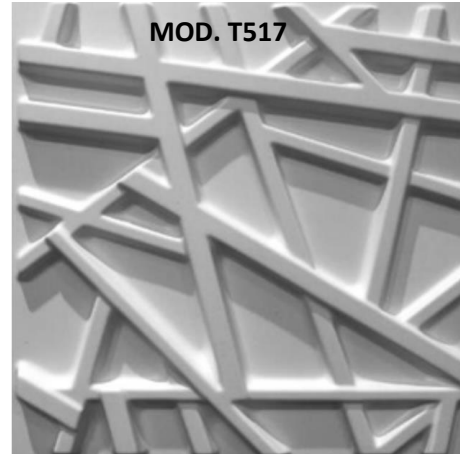

DISEÑA TUS ESPACIOS.  
.....INSTALA EN MINUTOS.....

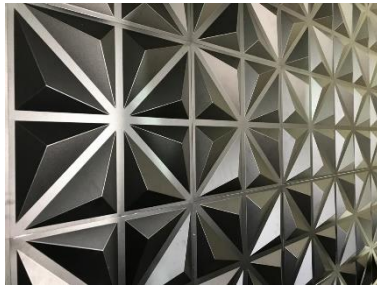

[www.cercasteldisenoyconstruccion.com](http://www.cercasteldisenoyconstruccion.com)

(771) 321 37 87



**Cercas-Tel**



# DISEÑO-CONSTRUCCIÓN

PROYECTOS ARQUITECTONICOS, MANTENIMIENTO,  
CONSTRUCCION , AMPLIACIÓN, REHABILITACION Y  
REMODELACION DE INMUEBLES.

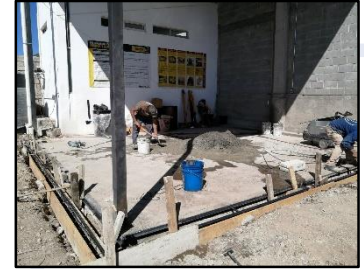

[www.cercasteldisenoyconstruccion.com](http://www.cercasteldisenoyconstruccion.com)

(771) 321 37 87



**Cercas-Tel**